

# Marsh-McBirney FLO-DAR® Area/Velocity Radar Flow Meter Sensor



*The Flo-Dar Sensor provides an ideal solution for non-contact, maintenance-free portable or permanent sewer flow monitoring.*

## Features and Benefits

The Flo-Dar Area/Velocity Radar Flow Meter provides a revolutionary approach to open channel flow monitoring. The sensor combines advanced Digital Doppler Radar velocity sensing technology with ultrasonic pulse echo depth sensing to remotely measure open channel flow. Use with FL900 Series Flow Logger or Flo-Logger/Logger XT for portable monitoring; for permanent monitoring sites, the Flo-Dar can be connected to the Flo-Station which displays flow rate, velocity, and level. (See Lit. No. 2709 [standard] or Lit. No. 2711 [wireless] for Flow Logger product information, or Lit. No. 2616 for Flo-Station product information). Intrinsically safe models available.

### Accurate Flow Measurement

Flo-Dar provides the user with highly accurate flow measurements under a wide range of flows and site conditions. By measuring the velocity of the fluid from above, Flo-Dar eliminates accuracy problems inherent with submerged sensors including sensor disturbances, high solids content and distribution of reflectors.

### Non-Contact Sensor Eliminates Lost Data

No lost data with non-contact, above the flow sensor that is unaffected by fouling due to debris and grease.

### Easy Installation and Maintenance

As the sensor is mounted above the flow, personnel have little or no contact with the flow during installation. Future sensor removal can be done without the need for confined space entry.

### Independent Accuracy / Long-Term Stability Verification

Flo-Dar sensor accuracy and long-term stability (up to 3 years without need for site calibration) from low flow depths up to surcharge conditions has been independently verified

many times over the years including a formal evaluation by the Alden Research Laboratory, Inc. and recent field evaluations done by municipalities and consulting engineering firms.

### Perfect Solution for Difficult Flow Conditions

Operates in the most difficult conditions including flows with high solids content, high temperature, shallow and caustic flows, large man-made channels, and high velocities up to 20 ft/s.

### Optional Surcharge Velocity Sensor

During surcharge events Flo-Dar's optional electromagnetic sensor will continue to provide uninterrupted and accurate flow monitoring through dry and wet weather flows without the need for routine sensor cleaning or maintenance.

### Applications

#### Municipal

- Sanitary Sewer Evaluation Studies
- Collection Systems
- Capacity Studies
- Combined Sewer Overflows
- Inflow and Infiltration (I&I) Studies
- Billing / Custody Transfer
- Plant Influent and Effluent

#### Industrial

- Process Waste
- Plant Influent
- Plant Effluent
- Non-contact Cooling Water
- Stormwater Monitoring and Compliance

DW = drinking water WW = wastewater municipal PW = pure water / power  
IW = industrial water E = environmental C = collections FB = food and beverage



Be Right™

WW

IW

C

## Specifications\*

### FLO-DAR SENSOR

#### Enclosure

IP68 Waterproof rating, Polystyrene

#### Dimensions

160.5 W x 432.2 L x 297 D mm (6.32 x 16.66 x 11.7 in.), with SVS, D = 387 mm (15.2 in.)

#### Weight

4.8 kg (10.5 lbs.)

#### Operating Temperature

-10 to 50°C (14 to 122°F)

#### Storage Temperature

-40 to 60°C (-40 to 140°F)

#### Power Requirements

Supplied by FL900 Flow Logger, Flo-Logger, or Flo-Station

#### Interconnecting Cable

**-Disconnectable at both sensor and logger or Flo-Station**

Polyurethane, 0.400 (±0.015) in. diameter; IP68  
Standard length 9M (30 ft), maximum 305 m (1000 ft)

Cables are available in two styles:

- connectors both ends
- connector from sensor with open leads to desiccant hub, desiccant hub with connector to logger. A potting/sealant kit will be included. This can be used to run the cable through conduit.

Important Note: The sensor cable assembly with desiccant hub is compatible with either the Marsh-McBirney Flo-Logger/Logger XT or the Hach FL900 Series Flow Loggers. When using this cable assembly with the Marsh-McBirney Flo-Logger, do not disconnect the desiccant cartridge that is attached to the Flo-Logger itself. It is important to keep the air tube plugged.

If using Flo-Dar cable with Flo-Station, the cable will have bare leads to the Flo-Station (30 to 1000 ft. lengths) and there will be no desiccant hub, as the air tube terminates inside of the Flo-Station housing.

#### Warranty

1 year

#### Set-up/Data Retrieval

Flo-Ware for Windows software is the user on-site set-up, data management, and report generation software. It is compatible with desktop/laptop computers utilizing Windows operating system.

#### Certification

The Flo-Dar Transmitter is certified to the following requirements:

- Transmitter type: Field Disturbance Sensor
- Frequency: 24.125 GHz - Doppler pulse
- Maximum rated power output: 128 dbuV (ave) @ 3 meters

Certified to: FCC Part 15.245: FCC ID: VIC-FLODAR24  
Industry Canada Spec. RSS210. v7: IC No.: 6149A-FLODAR24

Use of this device is subject to the following conditions:

1. There are no used serviceable items inside this device.
2. The user must install this device in accordance with the supplied installation instructions and must not modify the device in any manner whatsoever.
3. Any service involving the transmitter must only be performed by Hach Company.
4. The user must ensure that no one is within 20 cm of the face of the transmitter when operating.

### SURCHARGE DEPTH MEASUREMENT

Auto zero function maintains zero error below 0.5 cm (0.2 in.)

#### Method

Piezo-resistive pressure transducer with stainless steel diaphragm

#### Range

3.5 m (138 in.), overpressure rating 2.5 x full scale

### VELOCITY MEASUREMENT

#### Method

Radar

#### Range

0.23 to 6.10 m/s (0.75 to 20 ft/s)

#### Frequency Range

24.075 to 24.175 G-Hz, 15.2mW (max.)

#### Accuracy

±0.5%; ±0.03 m/s (±0.1 ft/s)

### DEPTH MEASUREMENT

#### Method

Ultrasonic

#### Standard Operating Range from Flo-Dar Housing to Liquid

0 to 152.4 cm (0 to 60 in.)

#### Optional Extended Level Operating Range from Transducer Face to Liquid

0 to 6.1 m (0 to 20 ft.) with 43.18 cm (17 in.) dead band, temperature compensated.

#### Accuracy

±1%; ±0.25 cm (±0.1 in.)

### FLOW MEASUREMENT

#### Method

Based on Continuity Equation

#### Accuracy

±5% of reading typical where flow is in a channel with uniform flow conditions and is not surcharged, ±1% full scale max.

### SURCHARGE CONDITIONS DEPTH/VELOCITY

#### DEPTH (Std with Flo-Dar Sensor)

Surcharge depth supplied by Flo-Dar sensor.

#### VELOCITY (Optional Surcharge Velocity Sensor)

#### Method

Electromagnetic

#### Range

±4.8 m/s (±16 ft/s)

#### Accuracy

±0.15 ft/s or 4% of reading, whichever is greater.

#### Zero Stability

> ±0.05 ft/s

### CERTIFICATION INTRINSICALLY SAFE

The Flo-Dar and Surcharge Velocity Sensors are certified to Class I, Zone 1 Standards. They conform to ANSI/UL 60079-11 and are certified to CAN/CSA E60079-11 and EN 60079-11 standards.



The Flo-Dar sensor meets CE requirements.

## Engineering Specifications

- The flow meter shall be capable of measuring level, average velocity and surcharge depth.
- The method of velocity measurement shall be Doppler radar.
- The sensor shall combine advanced Doppler Radar velocity sensing technology with ultrasonic pulse echo depth sensing to remotely measure open channel flow.
- Flow shall be calculated based on the Continuity Equation ( $Q=V \times A$ ), where  $Q$ =Flow,  $V$ =Average Velocity and  $A$ =Area.
- The range of velocity measurement shall be 0.23 to 6.10 m/s (0.75 to 20 ft/s).
- The method of depth measurement shall be ultrasonic.
- The standard operating range for depth measurement shall be 0 to 152.4 cm (0 to 60 in.) with an optional operating range of 0 to 6.1 m (0 to 20 ft.) with 43.18 cm (17 in.) deadband, temperature compensated.
- The flow meter shall have a surcharge condition velocity sensor option.
- Exterior dimensions of the sensor shall not exceed 160.5 W x 432.2 L x 297 D mm (6.32 W x 16.66 L x 11.7 D in.) or 160.5 W x 432.2 L x 387 D mm (6.32 W x 16.66 L x 15.2 D in.) with Surcharge Velocity option.
- The sensor shall be able to measure bi-directional surcharge flow.
- Optional Intrinsically Safe models available for flow monitoring in hazardous locations.
- The model shall be the Marsh-McBirney Flo-Dar Open Channel Flow Meter Sensor.

## Dimensions

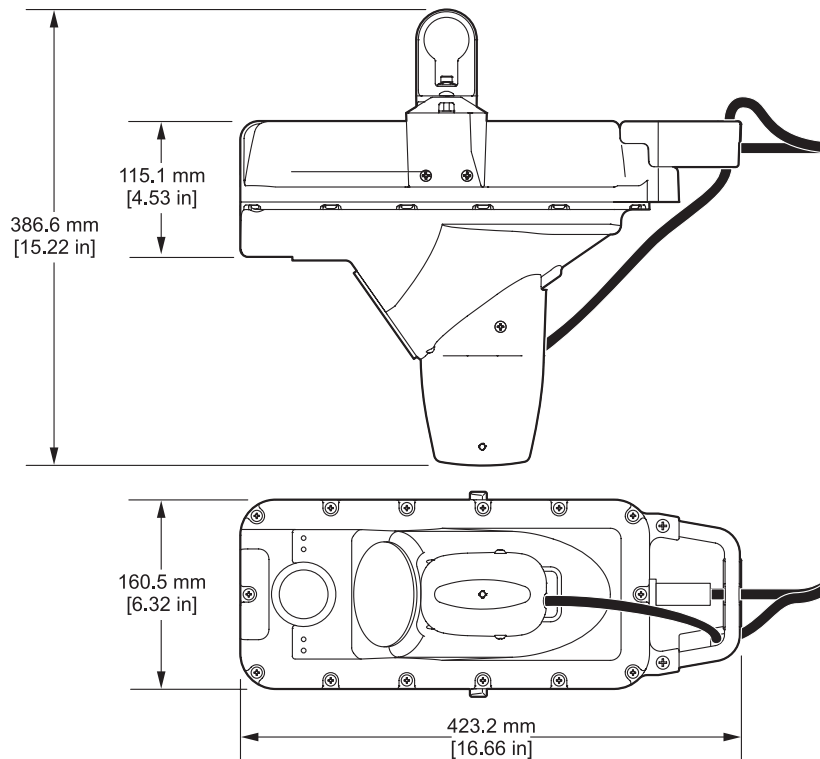

*Flo-Dar Area/Velocity Radar Flow Meter*

The desiccant hub assembly includes a junction box to connect sensor cable to the desiccant and subsequently to the FL900 Logger. The desiccant can easily be replaced without need to purchase a separate desiccant module.

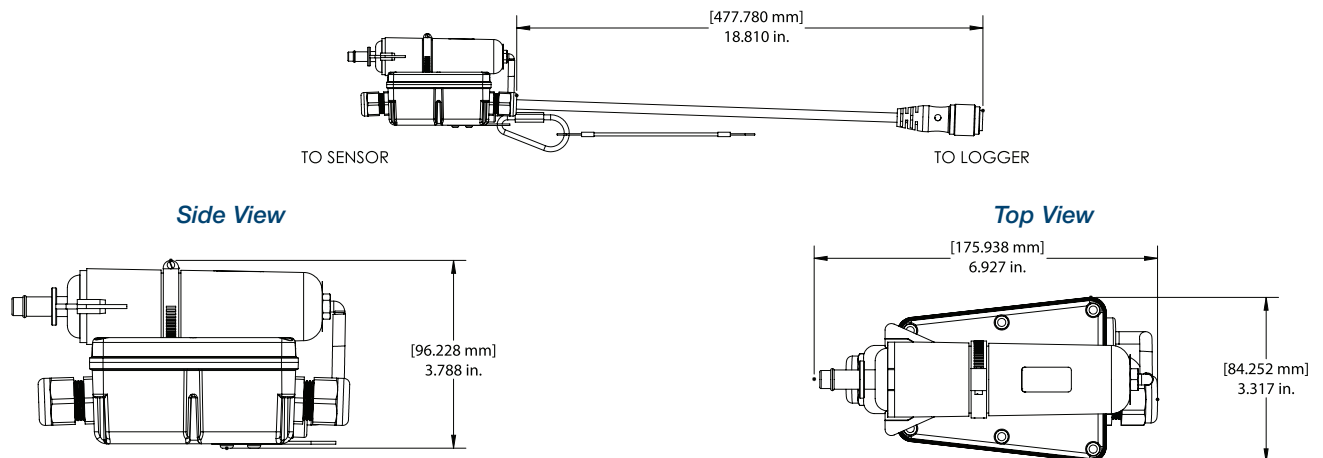

*Desiccant Hub Assemblies for use with portable FL900 Series Loggers and Flo-Logger.  
(Sensor cable for use with Flo-Station will not contain a desiccant hub and will have bare wires on cable end.)*

## Ordering Information

### Configure FLO-DAR Sensor to Logger (Portable)

Flo-Dar Sensor	Model 4000	-	4	X	X
<b>Flo-Dar Sensor with specified cable length</b> (need to add cable as separate line item)			4		
<b>Non Intrinsically Safe</b> <b>Surcharge Velocity Sensor Option</b> (IMPORTANT NOTE: SVS cable length MUST MATCH FloDar Sensor Cable length)				0 3	
<b>Non Extended Range</b> <b>Extended Range Option</b> —Allows use in flow depths up to 18 feet. Allow for 18" deadband. Standard unit max depth is 60". SVS Option requires Remote Extended Range below.					0 1
<b>Remote Extended Range Option with 6' sensor cable</b> —Flow depths up to 18 feet. Allow for 18" deadband. Standard unit max depth is 60".					2

### Configure FLO-DAR Sensor to Flo-Station (Permanent)

Flo-Dar Sensor	Model 4000	-	9	X	X
<b>Flo-Dar Sensor with specified cable length</b> (need to add cable as separate line item)			9		
<b>Non Intrinsically Safe</b> <b>Surcharge Velocity Sensor Option</b> (IMPORTANT NOTE: SVS cable length MUST MATCH Flo-Dar Sensor Cable length)				0 3	
<b>Non Extended Range</b> <b>Extended Range Option</b> —Allows use in flow depths up to 18 feet. Allow for 18" deadband. Standard unit max depth is 60". SVS Option requires Remote Extended Range below.					0 1
<b>Remote Extended Range Option with 6' sensor cable</b> —Flow depths up to 18 feet. Allow for 18" deadband. Standard unit max depth is 60".					2

### Cables

<b>FD9000CBL-XXX*</b>	FL900 Series Logger to Flo-Dar sensor. Cable w/two connectors.
<b>FDJCTBOXCBL-XXX*</b>	FL900 Series Logger to Flo-Dar sensor. Cable with connector to sensor, open end to desiccant hub, desiccant hub with connector to sensor. Includes finishing kit for potting/sealing desiccant hub. For use with conduit.
<b>6000062XX*</b>	SVS Sensor with connector for use with FL900 Series Logger.
<b>570011800-XXX*</b> <b>Model 4000-9</b>	Flo-Station to Flo-Dar sensor Cable with one connector and bare leads.
<b>6000059XX*</b>	SVS Sensor with bare leads for use with Flo-Station. *Contact customer service for product numbers.
Available Cable Lengths (in feet)	
30	125 225 400 700
60	150 250 450 800
75	175 300 500 900
100	200 350 600 1000

See Lit. No. 2709 (standard models) and Lit. No. 2711 (wireless models) for FL900 Series Flow Logger ordering information. See Lit. No. 2616 for Flo-Station ordering information.

### Mounting Hardware

<b>800016701</b>	Permanent Sensor Mount—Includes sensor frame & all mounting hardware. Portable Sensor Mounts Available (Sizes 34-107") Contact Sales.
------------------	---

### Accessories & Spares

<b>245000501</b>	Sensor Retrieval Pole - Used to place and retrieve sensor from mounting bracket. Pole extends to 7.3 m (21 ft.)
<b>510012701</b>	Sensor Retrieval Hook - Used with Sensor Retrieval Pole
<b>570011401</b>	Grounding Strap (required with Retrieval Pole and Hook when used with IS units)
<b>8755500</b>	Bulk desiccant beads (1.5 pounds)

Lit. No. 2708 Rev 2  
K11 Printed in U.S.A.

©Hach Company, 2011. All rights reserved.

In the interest of improving and updating its equipment, Hach Company reserves the right to alter specifications to equipment at any time.



At Hach, it's about learning from our customers and providing the right answers. It's more than ensuring the quality of water—it's about ensuring the quality of life. When it comes to the things that touch our lives...

Keep it pure.

Make it simple.

Be right.

For current price information, technical support, and ordering assistance, contact the Hach office or distributor serving your area.

In the United States and all other countries except Europe, contact:

HACH COMPANY  
4539 Metropolitan Court  
Frederick, MD 21704-9452, U.S.A.  
Telephone: 800-368-2723  
Fax: 301-874-8459  
E-mail: hachflowsales@hach.com  
[www.hachflow.com](http://www.hachflow.com)

In Europe contact:

Flow-Tronic  
Rue J.H. Cool 19a  
B-4840 Welkenraedt Belgium  
Telephone: +32-87-899799  
Fax: +32-87-899790  
E-mail: site@flow-tronic.com  
[www.flow-tronic.com](http://www.flow-tronic.com)



Be Right™