

# Sigma 911 CSA or ATEX Area Velocity Flow Meter



*The Sigma 911 CSA or Sigma 911 ATEX Area Velocity Flow Meter is ideal for short-term flow studies in hazardous or potentially hazardous environments. It features quick installation, minimal maintenance, and uses advanced Doppler technology that is accurate in low-level, full-pipe, and reversed-flow conditions. Corrections for the effects of temperature and velocity further enhance the Sigma 911 flow meter's accuracy.*

WW

## Features and Benefits

### CSA-NRTL/C Certified

The Sigma 911 CSA Area Velocity Flow Meter is CSA-NRTL/C certified for operation in Class I, Division 1, Groups C & D hazardous locations.

### ATEX Certified

The Sigma 911 ATEX Area Velocity Flow Meter is certified in accordance with the ATEX directive 94/9/EC by Zelm Ex for use in potential explosive atmospheres.

### Easy Installation and Maintenance

The slender 6.5-inch diameter data logger of the Sigma 911 flow meter means it can install almost anywhere. The Submerged Area Velocity sensor is easy to install and requires little maintenance. Single point calibration can be performed on-site without a bucket of water! The bottom face of the probe is beveled to eliminate the need for additional mounting clips in 8- and 10-inch pipes. An optional oil-filled probe greatly reduces sensor fouling and associated maintenance.

### Ideal for Harsh Environments

The data logger for the Sigma 911 flow meter is NEMA 6P sealed to withstand rugged sewer and storm water

environments including submergence and prolonged surcharge conditions. Its compact size makes it highly portable and easy to store.

### Advanced Technology for Accuracy

The Sigma 911 flow meter uses a patented\* "Drawdown Correction" feature that corrects the effects of velocity on accurate level measurement. Advanced, ultrasonic one-MHz Doppler technology avoids signal dropouts and ensures—without the need for on-site calibration—high levels of accuracy in low-flow, full-pipe, or reversed-flow conditions. A hydrodynamically shaped sensor and side-mounted cable reduce turbulence to ensure optimum monitoring performance.

### Applications

The Sigma 911 CSA or Sigma Model 911 ATEX Area Velocity Flow Meter is ideal for short-term flow studies in hazardous or potentially hazardous areas, sanitary sewer evaluation studies, Combined Sewer Overflows (CSO) studies, and industrial discharge monitoring.

\*Patent pending.

IW

C

DW = drinking water WW = wastewater municipal PW = pure water / power  
IW = industrial water E = environmental C = collections FB = food and beverage



Be Right™

## Specifications\*

### Flow Meter Data Logger

#### Units of Measurement

Level: m, cm, ft., in.

Flow: gps, gpm, gph, lps, lpm, lph, mgd, afd, cfs, cfm, cfh, cfd, m<sup>3</sup>s, m<sup>3</sup>m, m<sup>3</sup>h, m<sup>3</sup>d

Totalized Flow: L, m<sup>3</sup>, ft.<sup>3</sup>, gal., acre-ft.,

#### Monitoring Intervals

1, 2, 3, 5, 6, 10, 12, 15, 20, 30, and 60 minutes

#### Operating Temperature

-18 to 60°C (0 to 140°F)

#### Storage Temperature

-40 to 60°C (-40 to 140°F)

#### Time-Based Accuracy

±1 second per day

#### User Interface

Optically isolated IBM-compatible PC

#### Program Memory

Non-volatile programmable flash, can be updated via RS-232 port

#### Data Storage

Capacity: 300 days of 1 level and 1 velocity reading at 15-minute recording intervals

Data Types: Level and velocity

Storage Mode: Wrap or slate

#### Communications

Serial connection via optically isolated interface to IBM compatible computer with Hach data analysis software

#### Enclosure Material

PVC

#### Enclosure Rating

NEMA 6P (IP67)

#### Certification

CSA-NRTL/C-Class I, Div. 1, Groups C & D

Intrinsically Safe

Zelm Ex approved  II 2 G EEx e q ia IIB T3

#### Power Source

One 12 V, 12 Ah lead-acid, rechargeable

#### Battery Life

240 days, typical with a 15-minute recording interval (assumes data download once per week, at 10°C (50°F); also affected by site conditions)

#### Sampler Output

Optically isolated, 6 to 12 Vdc pulse, 100 mA max, at 500 ms duration flow proportional

#### Dimensions

16.5 cm diameter x 57 cm (6.5 in. diameter x 22.5 in.)

#### Weight

CSA version: 8.6 kg (20 lbs.) ATEX version: 11.3 kg (25 lbs.)

### Submerged Area/Velocity Sensor Specifications

#### VELOCITY MEASUREMENT

##### Range

-1.52 to 6.10 m/s (-5 to 20 ft./s)

##### Zero Stability

0.015 m/s (<0.05 ft./s)

##### Accuracy

±2% of reading

##### Typical Minimum Depth for Velocity

2 cm (0.8 in.)

##### Method

Doppler ultrasonic

##### Transducer Type

Twin 1 MHz piezoelectric crystals

#### LEVEL MEASUREMENT

##### Range

Standard: 0 to 3 m (0 to 10 ft.)

Extended: 0 to 9 m (0 to 30 ft.)

##### Accuracy (static)<sup>1</sup>

±0.16 % full scale ±1.5 % of reading at constant temperature (±2.5°C)

±0.20 % full scale ±1.75 % of reading from 0 to 30°C

±0.25 % full scale ±2.1 % of reading from 0 to 70°C

#### Allowable Level

Standard: 10.5 m (34.5 ft.)

Extended: 31.5 m (103.5 ft.)

#### Operating Temperature

0 to 70°C (32 to 158°F)

#### Compensated Temperature

0 to 30°C (32 to 86°F) level compensated

#### Velocity-Induced Error on Depth (Drawdown Correction—patent pending)

Compensated based on pipe geometry and flow velocity

#### Air Intake

Atmospheric pressure reference is desiccant protected

#### Method

Pressure transducer with stainless steel diaphragm

#### GENERAL

##### Material

Noryl<sup>®</sup> outer shell with epoxy potting

##### Power Consumption

Less than 1.2 W at 12 Vdc

##### Cable

Material: Urethane sensor cable with air vent

Connector: hard anodized; satisfies Military Spec 5015

##### Cable Dimensions

###### Length:

Standard— choice of 9, 15, 23, and 30.5 m (30, 50, 75, and 100 ft.)  
Custom— 30.75-76 m (101-250 ft. maximum)

Diameter: 0.91 cm (0.36 in.)

##### Sensor Dimensions

2.3 x 3.8 x 13.5 cm (0.9 x 1.5 x 5.31 in.) (for temperatures above 40°C add ±0.3 cm/°C)

## Engineering Specifications

1. The flow meter shall utilize one sensor to measure depth and velocity.
2. The flow meter shall utilize an ultrasonic Doppler sensor for measurement of average stream velocity and an integral level transducer for depth measurement.
3. The meter shall be microprocessor and EPROM structured with the ability to upload software updates in the field or via modem without the need to ship the meter to the factory.
4. The meter and sensor shall be CSA-NRTL/C certified for Class I, Division 1, Groups C & D hazardous locations or certified by Zelm Ex for use in Potential Explosive Atmospheres in accordance with ATEX directive 94/9/EC.
5. The data logger shall be housed in an UV resistant PVC enclosure rated NEMA 6P for prolonged submergence.
6. Overall flow meter data logger dimensions including batteries shall not exceed 6.5 inches diameter by 22.5 inches length.
7. The meter shall be programmed through an optically isolated RS-232 interface.
8. Applications:
  - a. For area x velocity applications, the flow meter shall be capable of computing flows in channels of circular, U-channel, rectangular, and trapezoidal cross sections.
  - b. For irregular channels, the flow meter shall be capable of storing in memory, two tables of up to 99 user entered (depth, area) points per table.
  - c. For level only applications, the flow meter shall be field programmable for primary devices including weirs, flumes, nozzle, Manning equation, power curve equation, and head vs. flow table.
9. The meter shall allow real-time modification of time (including PC synchronization), level and level calibration without other changes and allow resetting the logger without losing programming set-ups.
10. The software shall have the ability to view real time meter status, download with a single keystroke, store data to individual files or database, merge site files, automatically append new data with old, save and program meters using templates for sites, view all settings on a single screen, and calculate simulated flow for different primary devices, levels, and velocities.
11. The flow meter shall be capable of storing at least 18,432 data points (300 days at 15 minute level and velocity logging intervals).
12. Slate and wrap-around data storage shall be field selectable. Once programmed, the meter with software shall display the total time available for data logging.
13. Logging intervals should include 1, 2, 3, 5, 6, 10, 12, 15, 20, 30 and 60 minute intervals. The meter shall have the intelligence to log data at logical times automatically, i.e. 5 minute intervals at 0:00, 0:05, 0:10, etc. so all data during analysis of multiple sites is from the identical interval and time. The logger shall have the ability to data log battery voltage as a separate parameter.
14. The meter shall operate 240 days at 15-minute logging intervals of level/flow and velocity including weekly data downloads utilizing a single 12-volt lithium battery pack.
15. The sensor shall be the Sigma 911 CSA/ATEX Area Velocity Flow Meter manufactured by Hach Company.

## Dimensions

The Sigma 911 CSA or Sigma 911 ATEX Area Velocity Flow Meter can be used in hazardous locations where combustible gases may be present. Mount the meter so that the connectors face down. When not in use, cover the connectors with their protective caps to prevent corrosion. Always use the appropriate manhole support bracket/spanner bar.

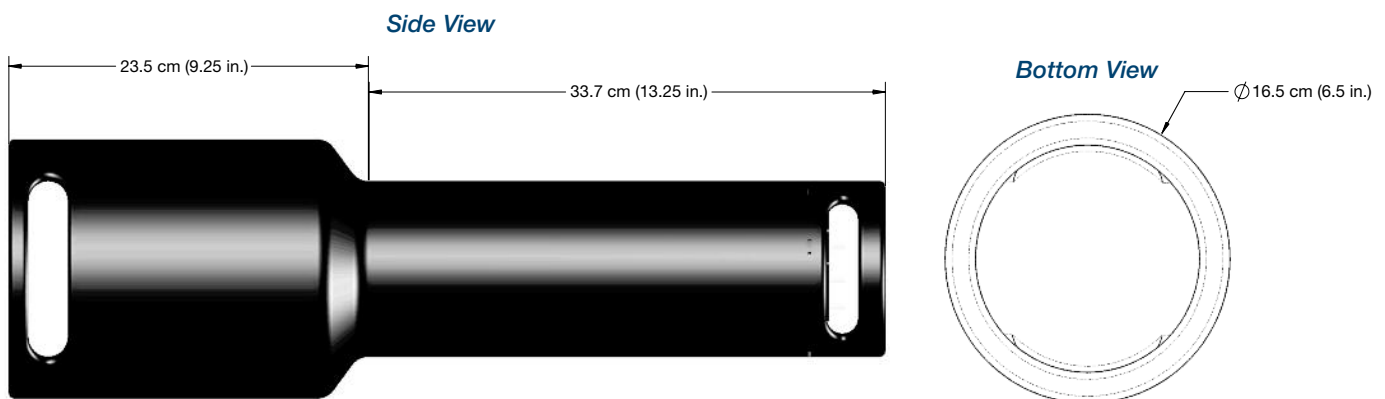

## Ordering Information

### Complete Flow Meter Systems

All Sigma CSA or ATEX Area Velocity Flow Meters include 512K of memory, one RS-232 port, one sampler port, and one rechargeable battery. For a complete flow meter, add a submerged AV sensor (listed below).

- 5150** Sigma 911 CSA Area Velocity Flow Meter, certified for hazardous locations
- 5151700** Sigma 911 ATEX Area Velocity Flow Meter

### Flow Meter Accessories

- 4920** Suspension Harness for suspending the flow meter
- 9542** Manhole Support Bracket/Spanner; 457 mm (18 in.), fits 457- to 711-mm (18- to 28-in.) manholes
- 9557** Manhole Support Bracket/Spanner; 711 mm (28 in.), fits 711- to 1219-mm (28- to 48-in.) manholes
- 5713000** Manhole Support Bracket; 457 to 685 mm (18 to 27 in.)
- 913** Charger; 115 Vac, gel electrolyte
- 915** Charger; 230 Vac, gel electrolyte
- 4087** RS-232 Intrinsic Safety Barrier, with 3 m (10 ft.) cable (contact Hach for longer lengths)
- 516001** Rechargeable Battery, for CSA-certified flow meter
- 6237000** Rechargeable Battery, for ATEX-certified flow meter

### Sensors

All sensors are equipped with a connector

#### Non-Oil Filled Standard Submerged Depth/Velocity (AV) Sensors (0 to 10 ft. range)

- 88065-030** Intrinsically Safe Submerged AV Sensor; 30 ft. cable
- 88065-050** Intrinsically Safe Submerged AV Sensor; 50 ft. cable
- 88065-075** Intrinsically Safe Submerged AV Sensor; 75 ft. cable
- 88065-100** Intrinsically Safe Submerged AV Sensor; 100 ft. cable

#### Non-Oil Filled Standard Submerged Depth/Velocity (AV) Sensors (0 to 30 ft. range)

- 88075-030** Intrinsically Safe Submerged AV Sensor; 30 ft. cable
- 88075-050** Intrinsically Safe Submerged AV Sensor; 50 ft. cable

- 88075-075** Intrinsically Safe Submerged AV Sensor; 75 ft. cable
- 88075-100** Intrinsically Safe Submerged AV Sensor; 100 ft. cable

#### Oil Filled Standard Submerged Depth/Velocity (AV) Sensors (0 to 10 ft. range)

- 88064-030** Intrinsically Safe Submerged AV Sensor; 30 ft. cable
- 88064-050** Intrinsically Safe Submerged AV Sensor; 50 ft. cable
- 88064-075** Intrinsically Safe Submerged AV Sensor; 75 ft. cable
- 88064-100** Intrinsically Safe Submerged AV Sensor; 100 ft. cable

#### Oil Filled Standard Submerged Depth/Velocity (AV) Sensors (0 to 30 ft. range)

- 88074-030** Intrinsically Safe Submerged AV Sensor; 30 ft. cable
- 88074-050** Intrinsically Safe Submerged AV Sensor; 50 ft. cable
- 88074-075** Intrinsically Safe Submerged AV Sensor; 75 ft. cable
- 88074-100** Intrinsically Safe Submerged AV Sensor; 100 ft. cable

### Sensor Mounting Hardware

- 4939** Submerged AV Mounting Plate, for pipe wall installation
- 9574** Insertion Tool for Street Level, for use with spring rings only

### Spring Bands

- 1361** Spring Band for 150 mm (6 in.) diameter pipe
- 1362** Spring Band for 200 mm (8 in.) diameter pipe
- 1363** Spring Band for 255 mm (10 in.) diameter pipe
- 1364** Spring Band for 300 mm (12 in.) diameter pipe

### Accessories

- 5254** Insight Software (included)
- 7724700** Silicon Oil; dual 50-mL pack (refills 100 sensors)
- 7724800** Silicon Oil Refill Kit; includes dispensing tool and oil packs
- 7725600** Oil-Filled Submerged AV Sensor Kit
- 7730000** Retrofit Kit (converts non oil-filled to oil-filled); includes kit Silicon Oil Refill Kit

**At Hach, it's about learning from our customers and providing the right answers. It's more than ensuring the quality of water—it's about ensuring the quality of life. When it comes to the things that touch our lives...**

**Keep it pure.**

**Make it simple.**

**Be right.**

**For current price information, technical support, and ordering assistance, contact the Hach office or distributor serving your area.**

*In the United States and all countries except Europe, contact:*  
**HACH COMPANY**  
 4539 Metropolitan Court  
 Frederick, MD 21704-9452, U.S.A  
 Telephone: (800) 368-2723  
 Fax: 301-874-8459  
 E-mail: hachflowsales@hach.com  
 www.hachflow.com

*In Europe for all countries except France, Spain and Great Britain:*  
**FLOW-TRONIC**  
 Rue J.H. Cool 19a  
 B-4840 Welkenraedt, Belgium  
 Telephone: +32-87-899797 or 899799  
 Fax: +32-87-899790  
 E-mail: info@flow-tronic.com  
 www.flow-tronic.com

*For France*  
**HACH LANGE FRANCE, S.A.S.**  
 8, mail Barthélemy Thimonnier  
 77185 LOGNES cedex  
 Telephone: 0 820 20 14 14 (In France)  
 (+33)(1) 69 67 34 00 (General)  
 Fax: (+33)(1) 69 67 34 99  
 E-mail: info@hach-lange.fr  
 www.hach-lange.fr

*For Spain*  
**HACH LANGE, S.L.U.**  
 Edif. Arteaga Centrum  
 C/Larrauri, 1C, 2ª Pl.  
 E-48160 Derio/Vizcaya  
 Telephone: (+34) 94 657 33 88  
 Fax: (+34) 94 657 33 97  
 E-mail: info@hach-lange.es  
 www.hach-lange.es

*For Great Britain*  
**HACH LANGE, LTD.**  
 Pacific Way/Salford  
 Manchester, M50 1DL  
 Telephone: (+44) 161 872 1487  
 Fax: (+44) 161 848 7324  
 E-mail: info@hach-lange.co.uk  
 www.hach-lange.co.uk

Lit. No. 2578 Rev 2

J10 Printed in U.S.A.

©Hach Company, 2010. All rights reserved.

In the interest of improving and updating its equipment, Hach Company reserves the right to alter specifications to equipment at any time.



**Be Right™**